



Submittal Data Sheet

AY-XP15CU / AE-X15CU

15,000 BTU Inverter Single Zone Wall Mounted Heat Pump

| | |
|------------|-------|
| Job Name: | |
| Reference: | Date: |

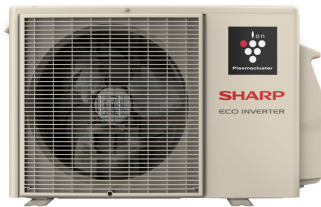

Product Features

- A2L refrigerant R32
- Energy Star Cold Climate certified
- High efficiency operation down to -22°F (-30°C)
- Safe "Hot Gas Pipe" de-icing system
- 50ft long "Coanda Airflow"
- "Multi Space" air circulation
- Built-in Wi-Fi Adapter



Sharp Air app available in Apple® App Store and Google® Play Store.

| CAPACITIES and POWER INPUT | | | |
|----------------------------|----------------------|---------|--------|
| Cooling at 95°F | Max. Capacity | BTU/H | 17,000 |
| | Rated Capacity | BTU/H | 15,000 |
| | Min. Capacity | BTU/H | 5,000 |
| | Max. Power Input | W | 1,350 |
| | Rated Power Input | W | 1,120 |
| | Moisture Removal | Pints/h | 3.2 |
| | Sensible Heat Factor | % | 80.6 |
| | Power Factor | % | 82 |
| Heating at 47°F | Max. Capacity | BTU/H | 21,800 |
| | Rated Capacity | BTU/H | 18,000 |
| | Min. Capacity | BTU/H | 4,500 |
| | Max. Power Input | W | 1,780 |
| Heating at 17°F | Rated Power Input | W | 1,300 |
| | Power Factor | % | 89 |
| | Max. Capacity | BTU/H | 18,100 |
| | Rated Capacity | BTU/H | 18,100 |
| Heating at 5°F | Max. Power Input | W | 2,400 |
| | Rated Power Input | W | 2,400 |
| | Max. Capacity | BTU/H | 15,300 |
| Heating at -4°F | Max. Power Input | W | 2,130 |
| | Max. Capacity | BTU/H | 13,200 |
| Heating at -13°F | Max. Capacity | BTU/H | 11,100 |
| Heating at -17°F | Max. Capacity | BTU/H | 10,100 |
| Heating at -22°F | Max. Capacity | BTU/H | 8,900 |

NOTE: Test conditions are based on AHRI 210/240.

| | |
|------------------|---|
| Cooling at 95°F | Indoor: 80°F (26.7°C) DB / 67°F (19.4°C) WB |
| | Outdoor: 95°F (35.0°C) DB / 75°F (23.9°C) WB |
| Heating at 47°F | Indoor: 70°F (21.1°C) DB / 60°F (15.6°C) WB |
| | Outdoor: 47°F (8.3°C) DB / 43°F (6.1°C) WB |
| Heating at 17°F | Indoor: 70°F (21.1°C) DB / 60°F (15.6°C) WB |
| | Outdoor: 17°F (-8.3°C) DB / 15°F (-9.4°C) WB |
| Heating at 5°F | Indoor: 70°F (21.1°C) DB / 60°F (15.6°C) WB |
| | Outdoor: 5°F (-15.0°C) DB / -3°F (-16.1°C) WB |
| Heating at -4°F | Indoor: 70°F (21.1°C) DB / 60°F (15.6°C) WB |
| | Outdoor: -4°F (-20.0°C) DB / -°F (-°C) WB |
| Heating at -13°F | Indoor: 70°F (21.1°C) DB / 60°F (15.6°C) WB |
| | Outdoor: -13°F (-25.0°C) DB / -°F (-°C) WB |
| Heating at -17°F | Indoor: 70°F (21.1°C) DB / 60°F (15.6°C) WB |
| | Outdoor: -17°F (-27.2°C) DB / -°F (-°C) WB |
| Heating at -22°F | Indoor: 70°F (21.1°C) DB / 60°F (15.6°C) WB |
| | Outdoor: -22°F (-30.0°C) DB / -°F (-°C) WB |

| EFFICIENCIES | | |
|------------------------------|--|-------------|
| SEER/SEER2 | | 24.0 / 24.0 |
| EER2 | | 13.4 |
| HSPF (IV) /HSPF2 (IV) | | 11.8 / 11.0 |
| HSPF (V) /HSPF2 (V) | | 9.5 / 8.7 |
| COP at 47F | | 4.06 |
| COP at 17F at Max. Capacity | | 2.21 |
| COP at 5F at Max. Capacity | | 2.1 |
| COP at -22F at Max. Capacity | | 1.7 |

| ELECTRICAL | | |
|-------------------------------------|------|----------------|
| Voltage, Phase, Frequency | | 208/230, 1, 60 |
| Guaranteed Voltage Range | V AC | 187 - 253 |
| Voltage: Indoor - Outdoor, S1-S2 | V AC | 208/230 |
| Voltage: Indoor - Outdoor, S2-S3 | V DC | 24 |
| Short-circuit Current Rating (SCCR) | KA | 5.0 |
| Rated Running Current (Cool/Heat) | A | 6.1 / 6.4 |
| MCA (Indoor/Outdoor) | A | 0.4/15.0 |
| Maximum Fuse Size (MOCP) | A | 20 |
| Circuit Breaker | A | 15 |
| Wire Size (Indoor - Outdoor) | AWG | 14 |

| COMPRESSOR | | |
|-----------------|---------|-----------------|
| Type | | Single Rotary |
| Model | A | KTN150D63UFZR3 |
| Rated Load Amps | A | 10.5 |
| Oil Type | | Ester Oil VG75r |
| Oil Charge | oz (ml) | 14.2 (420) |

| PIPING | | |
|--------------------------------|----------|------------------|
| Gas Pipe Size O.D. (Flared) | In. (mm) | 3/8 (9.52) |
| Liquid Pipe Size O.D. (Flared) | In. (mm) | 1/4 (6.35) |
| Chargeless Piping Length | Ft. (m) | 25 (7.6) |
| Min.-Max Pipe Length | Ft. (m) | 10 (3) - 66 (20) |
| Maximum Height Difference | Ft. (m) | 33 (10) |

| REFRIGERANT | | |
|----------------------------------|---------------|-----------------|
| Type | | R32 |
| Refrigerant Control | | Expansion Valve |
| Charge | oz. (g) | 36 (1020) |
| Additional Charge of Refrigerant | oz./Ft. (g/m) | 0.16 (15) |
| Defrost Method | | Reverse Cycle |
| De-icing System | | Hot Gas Pipe |

| FAN and SOUND | | Indoor Unit | Outdoor Unit |
|--------------------------------|-------|-----------------------------|---------------|
| Fan | | Cross Flow Fan | Propeller Fan |
| Fan Motor Full Load Amperage | A | 0.4 | 0.7 |
| Fan Motor Output | W | 30 | 41 |
| Airflow Rate at Cooling, Dry | CFM | 636 / 558 / 441 / 328 / 251 | |
| Airflow Rate at Cooling, Wet | CFM | 579 / 508 / 401 / 298 / 228 | 1102 |
| Airflow Rate at Heating, Dry | CFM | 674 / 597 / 505 / 413 / 251 | |
| Sound Pressure Level (Cooling) | dB(A) | 46 / 42 / 38 / 30 / 26 | 49 |
| Sound Pressure Level (Heating) | dB(A) | 46 / 42 / 36 / 30 / 23 | 50 |

| DIMENSION and WEIGHT | | Indoor Unit | Outdoor Unit |
|----------------------|---------------------|--|---|
| Unit Dimensions | W x H x D: In. (mm) | 41.4 x 12.4 x 9.8 (1052 x 316 x 249) | 30.7 x 21.3 x 10.6 (780 x 540 x 269) |
| Package Dimensions | W x H x D: In. (mm) | 43.8 x 12.7 x 15.3 (1113 x 323 x 389) | 36.3 x 23.8 x 15.5 (922 x 603 x 393) |
| Unit Weight | lbs. (kg) | 31 (14) | 67 (30) |
| Package Weight | lbs. (kg) | 35 (16) | 73 (33) |

| OPERATING TEMPERATURE | | Indoor Unit | Outdoor Unit |
|--|---------|-----------------------|-----------------------|
| Cooling (Max. / Min.) | °F (°C) | 90 / 70 (32.2 / 21.1) | 115 / 14 (46.1 / -10) |
| Cooling Thermal Lock-out / Re-start Temperatures | °F (°C) | - | - |
| Heating (Max. / Min.) | °F (°C) | 81 / - (27.2 / -) | 75 / -22 (23.9 / -30) |
| Heating Thermal Lock-out / Re-start Temperatures | °F (°C) | - | -22 (-30) |

| OTHERS | | Indoor Unit | Outdoor Unit |
|---------------------------|----------|----------------|-------------------------------|
| Drain Pipe Size | In. (mm) | - | φ0.67 and φ0.79 (φ17 and φ20) |
| External Finish Color | | Premium White | Warm Beige |
| Coating on Heat Exchanger | | Normal Coating | Blue Fin Coating |

NOTE: Test conditions are based on AHRI 210/240.

DIMENSIONS: AY-XP15CU / AE-X15CU

Indoor Unit

Length unit: inch (mm)

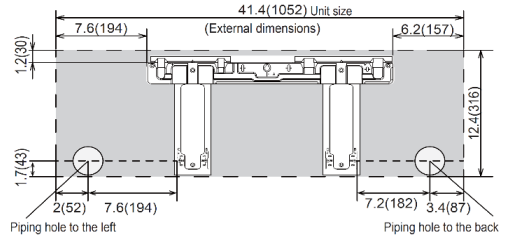
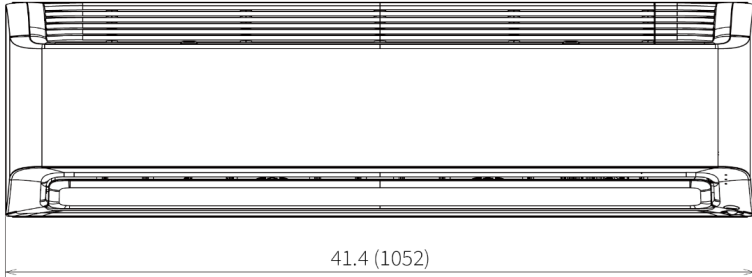
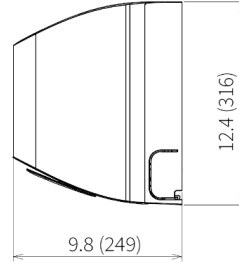
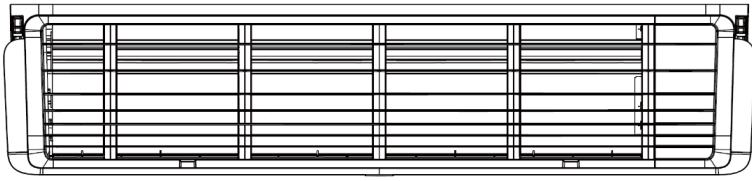

Outdoor Unit

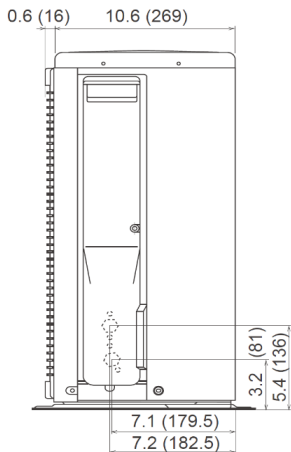
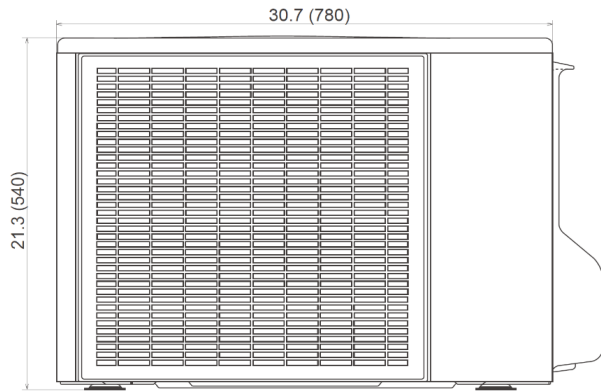
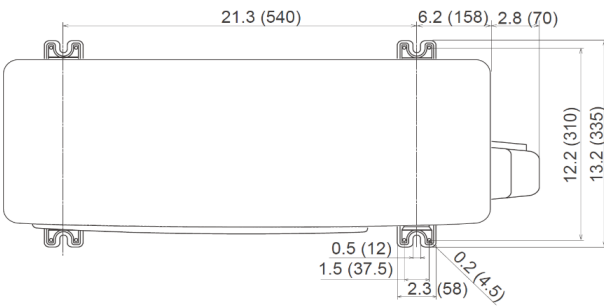

Required Space

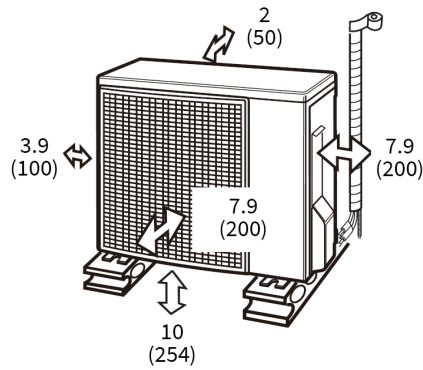

SHARP

Sharp Corporation, Japan
2-1-25, Kyutaromachi, Chuo-ku, Osaka
541-8522

